

# RANGER MC ST

SUBMERSIBLE PUMPS IN STAINLESS STEEL



## DOUBLE-CHANNEL

-  Filthy water
-  Domestic use
-  Civil use
-  Industrial use



## PERFORMANCE RANGE

- Flow rate up to **750 l/min** (45 m<sup>3</sup>/h)
- Head up to **15 m**

## APPLICATION LIMITS

- **5 m** maximum immersion depth
- Maximum liquid temperature **+40 °C**
- Passage of suspended solids up to **Ø 50 mm**
- Minimum immersion depth for continuous service: **300 mm**

## CONSTRUCTION AND SAFETY STANDARDS

The pumps are complete with:

- power cable
- float switch for single-phase versions

EN 60335-1  
IEC 60335-1  
CEI 61-150

EN 60034-1  
IEC 60034-1  
CEI 2-3



## CHARACTERISTIC CURVES AND PERFORMANCE DATA

50 Hz | n=2900 min<sup>-1</sup>

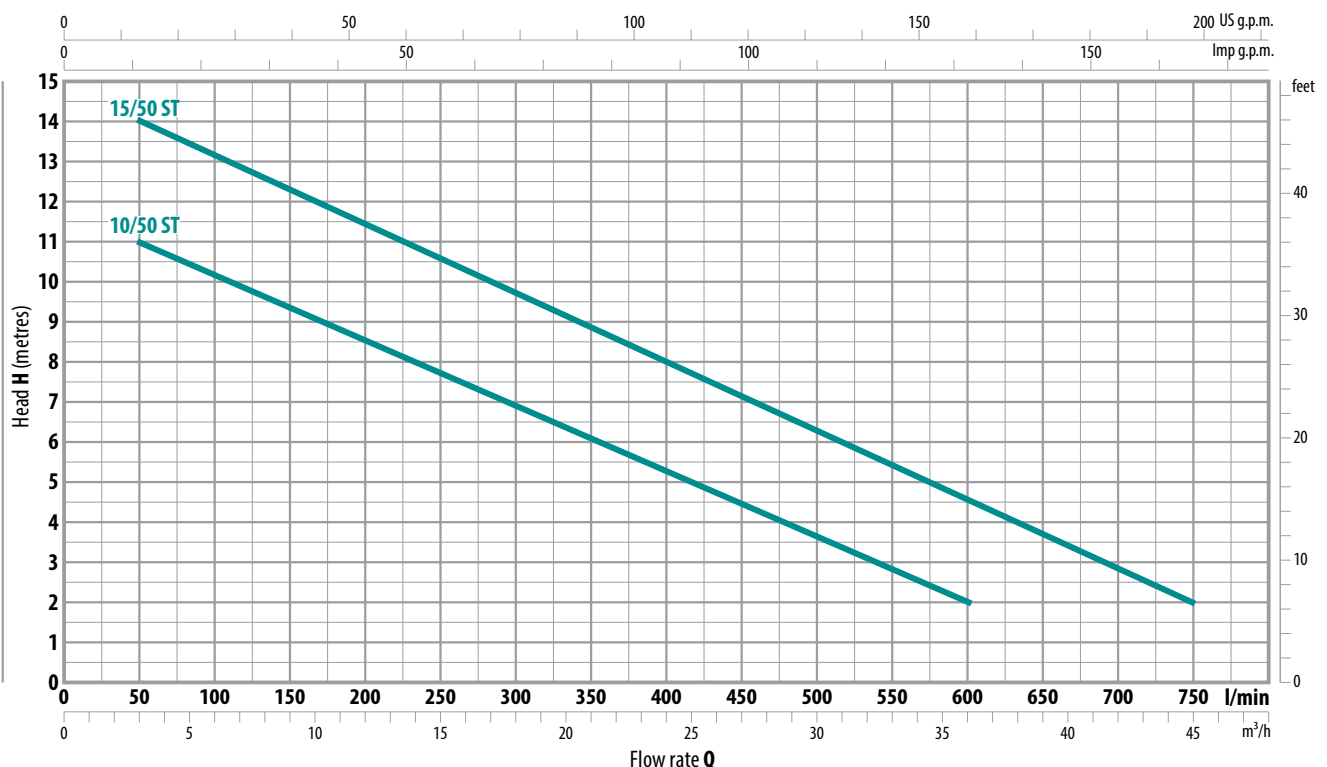

MODEL		POWER (P <sub>2</sub> )		Q	Flow rate									
Single-phase	Three-phase	kW	HP		m <sup>3</sup> /h	0	3	6	12	18	24	30	36	42
				l/min	0	50	100	200	300	400	500	600	700	750
RANGER MC 10/50M ST	RANGER MC 10/50 ST	0.75	1	H metres	12	11	10	8.5	7	5	3.6	2		
RANGER MC 15/50M ST	RANGER MC 15/50 ST	1.1	1.5		15	14	13	11.5	9.7	8	6.3	4.6	2.9	2

Q = Flow rate  
H = Total manometric head

Tolerance of characteristic curves in compliance with EN ISO 9906 Grade 3B.

## INSTALLATION AND USE

RANGER MC ST submersible pumps in stainless steel are recommended for draining dirty and filthy water in domestic, civil and industrial applications. They come equipped with a DOUBLE-CHANNEL impeller and are capable of pumping liquids containing short fibred suspended solids up to Ø 50 mm. They are ideal for pumping sewage, waste water, surface water and water mixed with mud in locations such as blocks of flats and detached houses.

These pumps distinguish themselves for their reliability, which can be best appreciated under automatic operating conditions in fixed installations.

## CONSTRUCTION CHARACTERISTICS

<b>PUMP BODY</b>	Stainless steel AISI 304 with threaded port in compliance with ISO 228/1
<b>IMPELLER</b>	Precision cast stainless steel AISI 304 DOUBLE-CHANNEL type
<b>MOTOR SHAFT</b>	Stainless steel AISI 431
<b>SHAFT WITH DOUBLE MECHANICAL SEAL SEPARATED BY AN OIL CHAMBER</b>	<b>Motor side:</b> Silicon carbide - Graphite - NBR <b>Pump side:</b> Silicon carbide - Silicon carbide - NBR
<b>POWER CABLE</b>	H07 RN-F type 10 m long power cable (with Schuko plug for single-phase versions only)

## DIMENSIONS AND WEIGHT

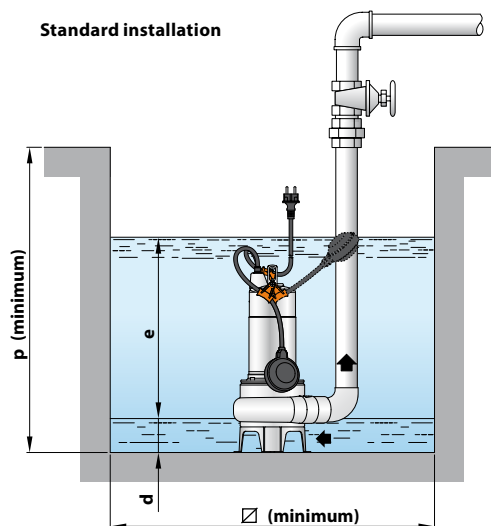
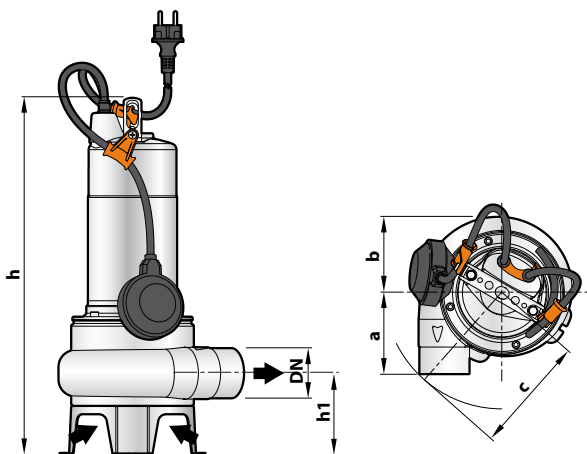

MODEL		PORT DN	Passage of solids	DIMENSIONS mm									kg	
Single-phase	Three-phase			a	b	c	h	h1	d	e	p	Ø	1~	3~
RANGER MC 10/50M ST	RANGER MC 10/50 ST	2"	Ø 50 mm	102	95	145	430	102	60	variable	500	500	11.9	10.8
RANGER MC 15/50M ST	RANGER MC 15/50 ST						445						13.5	12.5

## ABSORPTION

MODEL	VOLTAGE		
	230 V	240 V	110 V
<b>Single-phase</b>			
RANGER MC 10/50M ST	5.0 A	4.8 A	10.0 A
RANGER MC 15/50M ST	8.2 A	7.9 A	-

MODEL	VOLTAGE			
	230 V	400 V	240 V	415 V
<b>Three-phase</b>				
RANGER MC 10/50 ST	3.7 A	2.1 A	3.5 A	2.0 A
RANGER MC 15/50 ST	5.6 A	3.2 A	5.4 A	3.1 A

## PALLETIZATION

MODEL		GROUPAGE n. pumps	CONTAINER n. pumps
Single-phase	Three-phase		
RANGER MC 10/50M ST	RANGER MC 10/50 ST	54	72
RANGER MC 15/50M ST	RANGER MC 15/50 ST	54	72